

MATERIALS

HOUSING: HI-TEMP. PLASTIC (UL 94V-0), BLACK
 INNER PIN: COPPER ALLOY, 5u" SILVER PLATING
 SHELL: SPCC, 20u" NICKEL PLATING
 TERMINAL: COPPER ALLOY, 50u" Sn-Cu ALLOY PLATING

SPECIFICATION

CURRENT RATING: 54V, 10 AMP MAX
 DIELECTRIC WITHSTANDING: 500V AC FOR ONE MINUTE
 CONTACT RESISTANCE: 50m OHMS MAX
 INSULATION RESISTANCE: 100M OHMS MIN AT DC 500V
 OPERATION TEMPERATURE: -45°C~+85°C

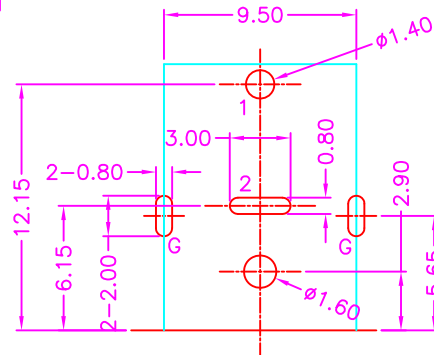
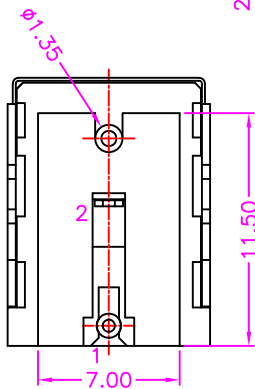
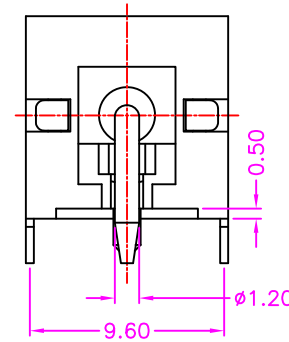
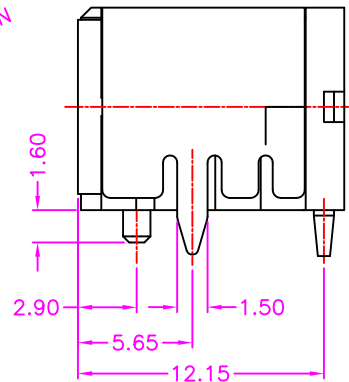
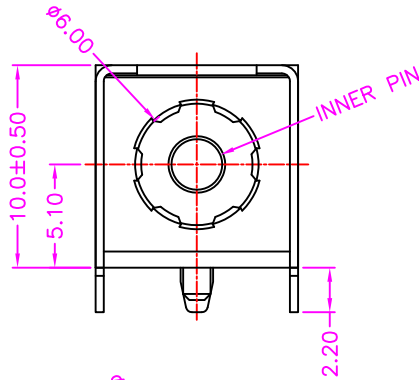

P.C.B LAYOUT
TOP VIEW ±0.05

PART NUMBER:

JPJDB - * - 1 * 2

SERIES

INNER PIN OPTION
 2: Ø2.50mm
 4: Ø2.00mm

PACKAGE OPTION
 1: TRAY
 2: TAPE REEL
 4: BAG

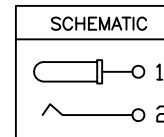

NOTE: 100PCS/TRAY, 1200PCS/12 TRAY/INNER BOX
6000PCS/ 5 INNER BOX/ CARTON

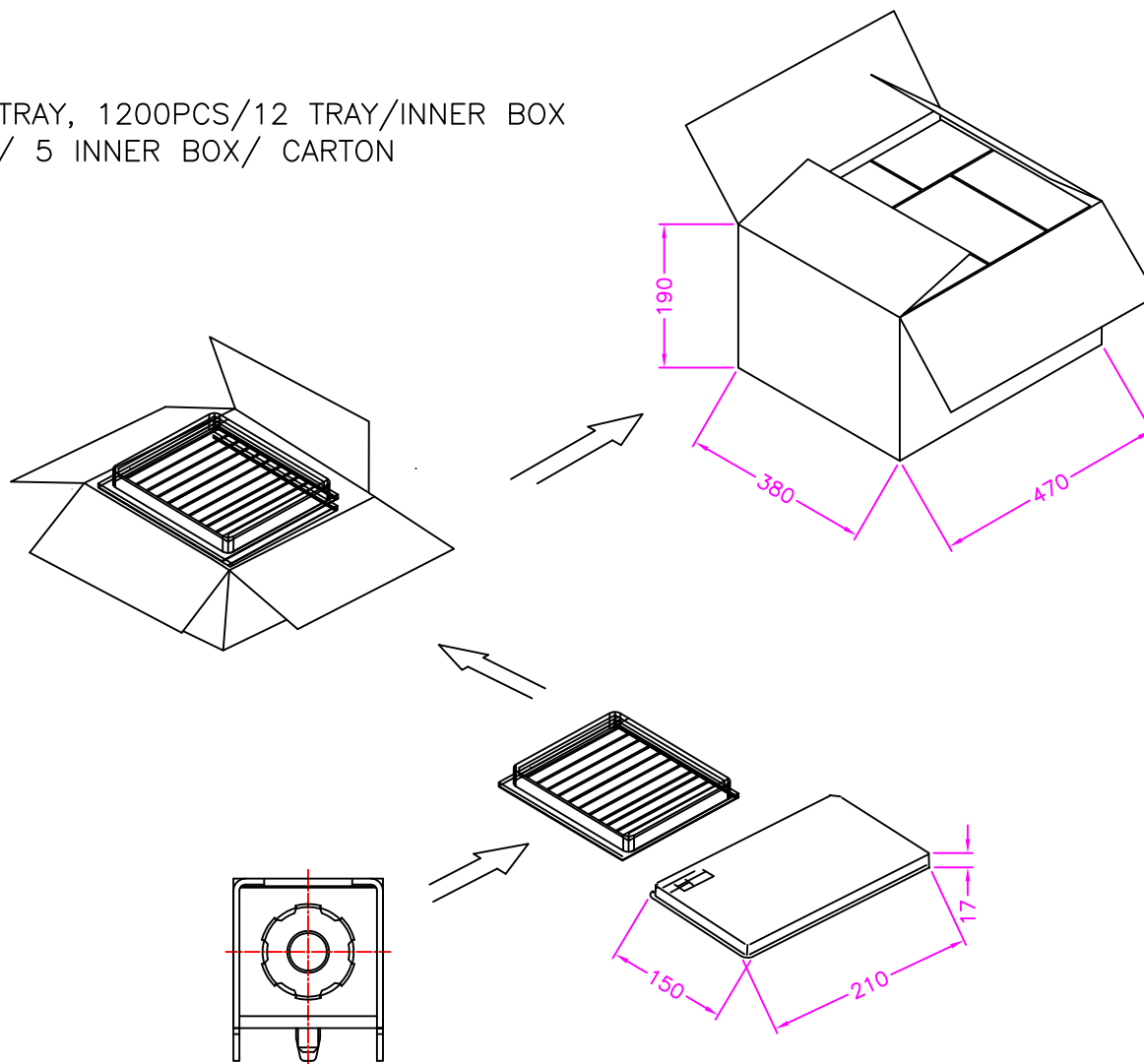

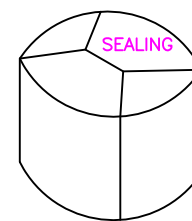
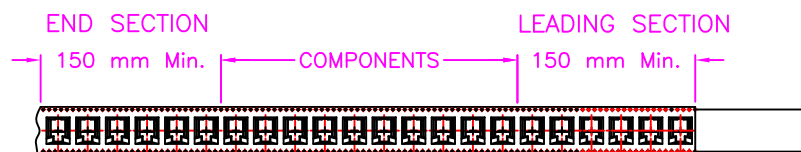
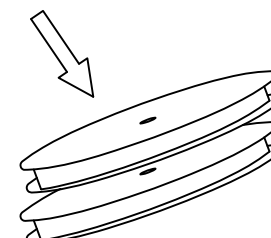
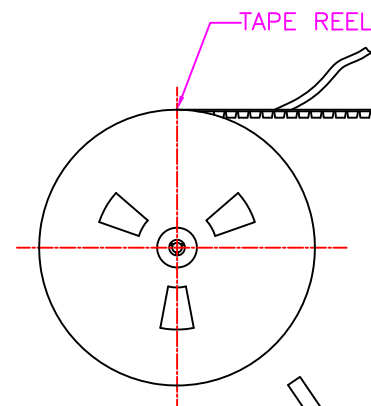
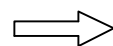
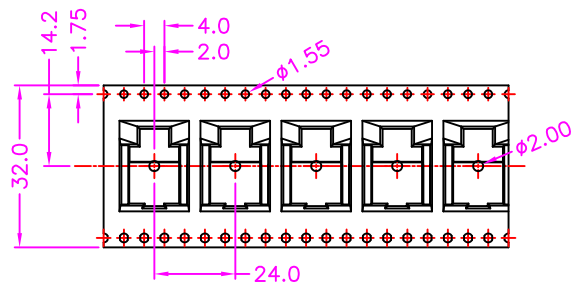
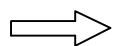
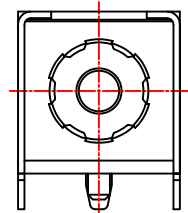

DESICCATING AGENTS

PE BAG

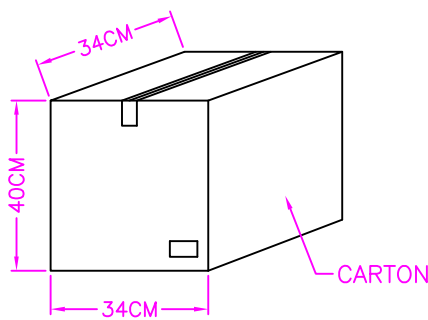
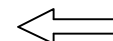
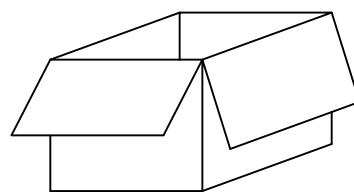
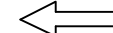
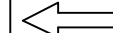
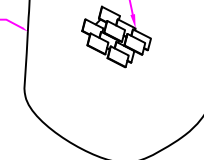

NOTE: 200PCS/REEL, 2000PCS/10 REEL/CARTON