

A

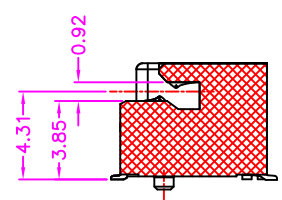

SECTION A-A
SCALE 2:1

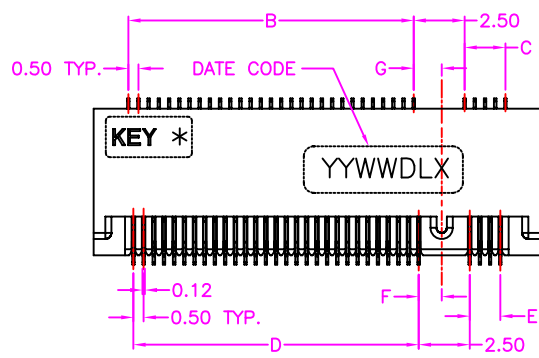
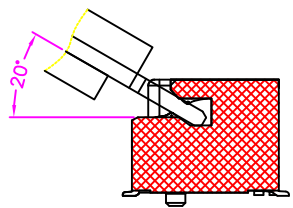

MATING SIMILAR

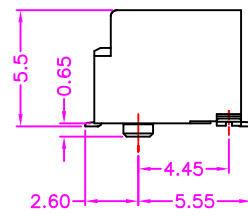

B

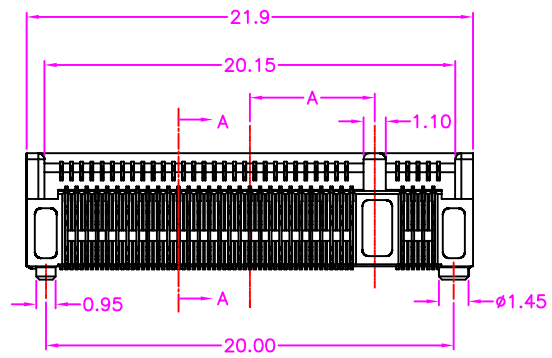

C

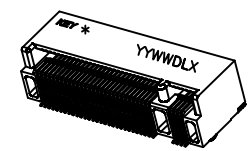
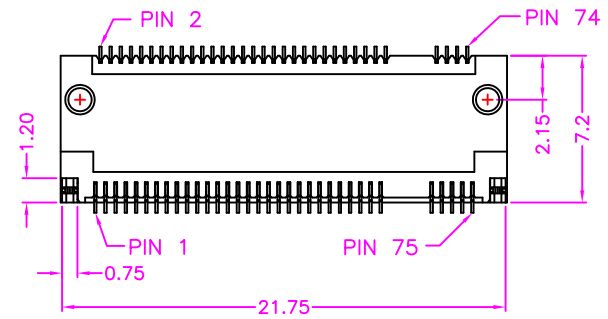

MATERIALS

HOUSING: HI-TEMP. PLASTIC (UL 94V-0), BLACK
 SOLDER PEG: STAINLESS STEEL, TIN PLATING
 TERMINAL: COPPER ALLOY, GOLD PLATED

SPECIFICATION

CURRENT RATING: 0.5 AMP MAX
 DIELECTRIC WITHSTANDING: 300V AC FOR ONE MINUTE
 CONTACT RESISTANCE: 55m OHMS MAX
 INSULATION RESISTANCE: 500M OHMS MIN AT DC 500V
 OPERATION TEMPERATURE: -40°C~+80°C

PART NUMBER:
MCEGT - 6 7 * - 1 2 4 *

SERIES — NO. OF POS. — CONTACT PLATED OPTION — KEY TYPE OPTION

1: GOLD FLASH
 3: 3u" GOLD
 5: 5u" GOLD
 6: 10u" GOLD
 7: 15u" GOLD
 9: 30u" GOLD

TAPE REEL PACKAGE

KEY TYPE OPTION:
 A: A TYPE
 B: B TYPE
 C: C TYPE
 D: D TYPE
 E: E TYPE
 F: F TYPE
 G: G TYPE
 H: H TYPE
 J: J TYPE
 K: K TYPE
 L: L TYPE
 M: M TYPE

M	PIN 59-66	-6.125	14.0	2.0	14.0	1.5	1.125	1.375		
L	PIN 55-62	-5.125	13.0	3.0	13.0	2.5	1.125	1.375		
K	PIN 51-58	-4.125	12.0	4.0	12.0	3.5	1.125	1.375		
J	PIN 47-54	-3.125	11.0	5.0	11.0	4.5	1.125	1.375		
H	PIN 43-50	-2.125	10.0	6.0	10.0	5.5	1.125	1.375		
G	PIN 39-46	-1.125	9.0	7.0	9.0	6.5	1.125	1.375		
F	PIN 28-35	1.625	6.5	9.5	6.0	9.5	1.375	1.125		
E	PIN 24-31	2.625	5.5	10.5	5.0	10.5	1.375	1.125		
D	PIN 20-27	3.625	4.5	11.5	4.0	11.5	1.375	1.125		
C	PIN 16-23	4.625	3.5	12.5	3.0	12.5	1.375	1.125		
B	PIN 12-19	5.625	2.5	13.5	2.0	13.5	1.375	1.125		
A	PIN 8-15	6.625	1.5	14.5	1.0	14.5	1.375	1.125		
MODULE CARD TYPE	DIM P	KEY ID	PAD REMOVED	DIM A	DIM B	DIM C	DIM D	DIM E	DIM F	DIM G

D

ZICONN
 ELECTRONIC CO., LTD.
 WWW.ZICONN.COM 886-3-4687695

TOLERANCES

X	±0.40	.XX	±0.20
.X	±0.30	.XXX	±0.10

REV. A DRAWN BY Zhong 2019/10/24

APPROVED BY Lion 2019/10/24

TITLE NGFF(M.2), 0.5mm PITCH, PCB MOUNT, SMT, 1 KEY WITH PAD H=5.50mm, FEMALE

DRAW NO. MCEGT-004 UNIT MM Sheet 1/3

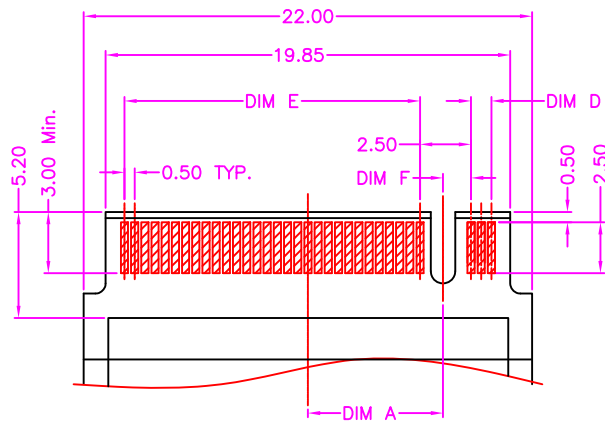

BOTTOM SIDE

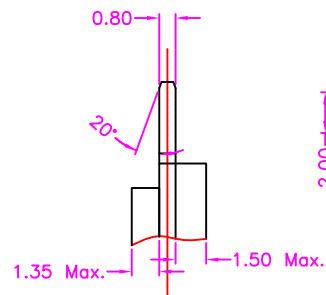

PLUG PCB

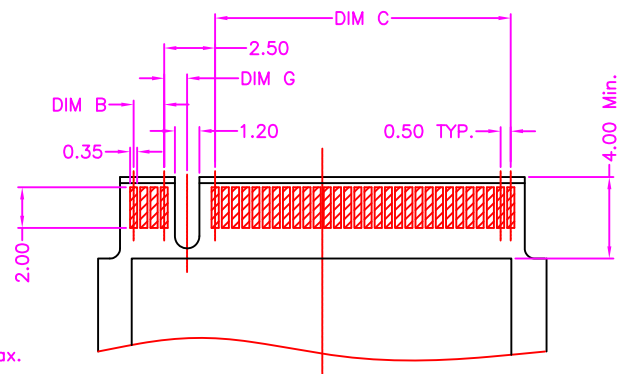

TOP SIDE

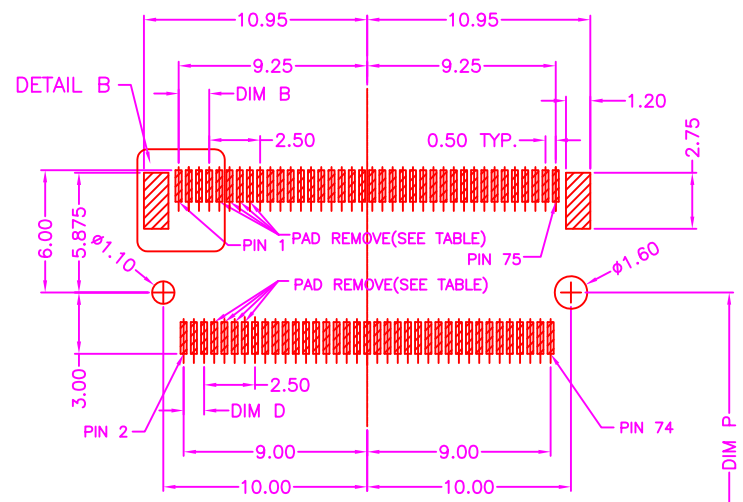

P.C.B. LAYOUT
TOP VIEW ± 0.05

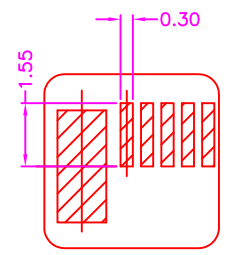

DETAIL B
SCALE 2:1

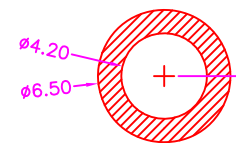

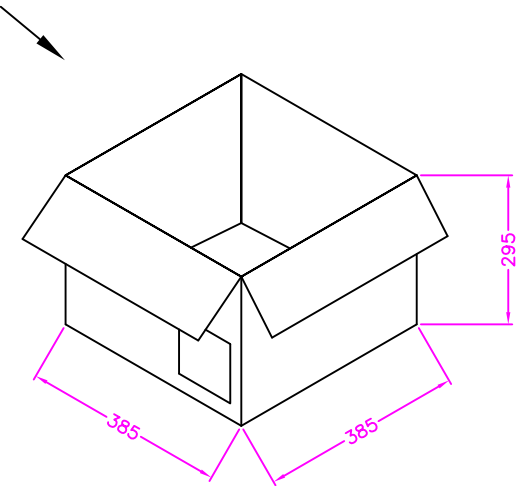
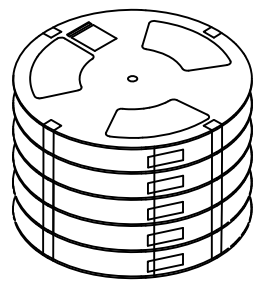
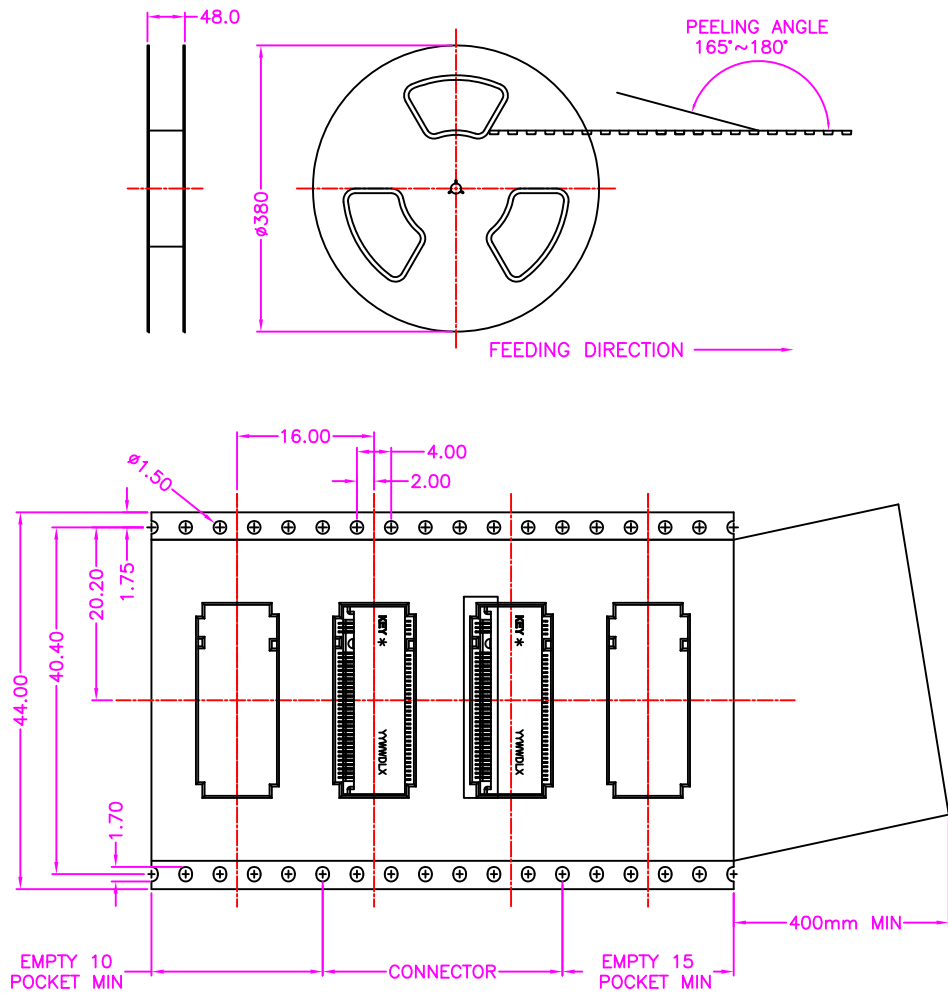

NOTE: 900PCS/ REEL, 4500PCS/ 5 REEL/ CARTON