

A

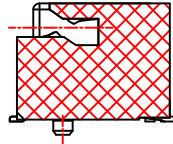

SECTION A-A
SCALE 1:1

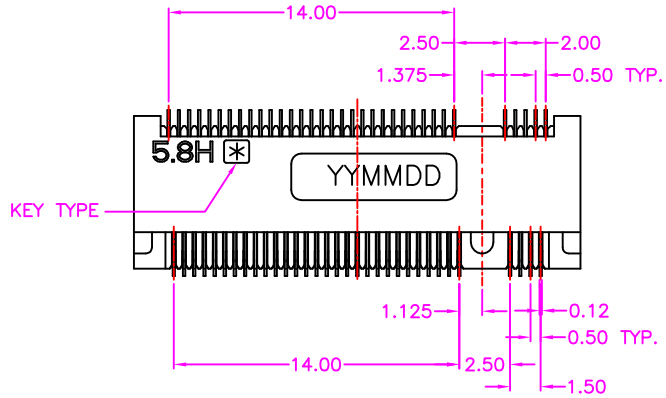
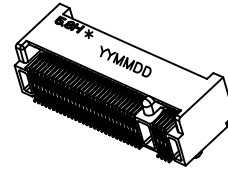

MATERIALS

HOUSING: HI-TEMP. PLASTIC (UL 94V-0), BLACK
 SOLDER PEG: STAINLESS STEEL, TIN PLATING
 TERMINAL: COPPER ALLOY, GOLD PLATED

SPECIFICATION

CURRENT RATING: 0.5 AMP MAX
 DIELECTRIC WITHSTANDING: 300V AC FOR ONE MINUTE
 CONTACT RESISTANCE: 55m OHMS MAX
 INSULATION RESISTANCE: 500M OHMS MIN AT DC 500V
 OPERATION TEMPERATURE: -40°C~+80°C

B

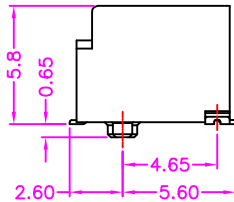
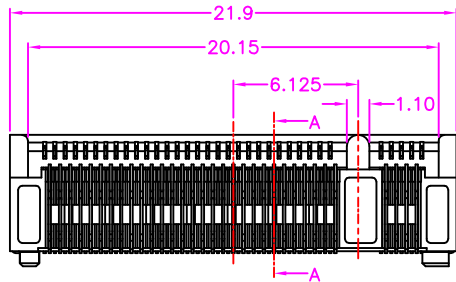

PART NUMBER:

MCEGT - 6 7 * - 1 2 5 *

SERIES ————
 NO. OF POS. ————
 CONTACT PLATED OPTION ————
 KEY TYPE OPTION
 A: A TYPE
 B: B TYPE
 C: C TYPE
 D: D TYPE
 E: E TYPE
 F: F TYPE
 G: G TYPE
 H: H TYPE
 J: J TYPE
 K: K TYPE
 L: L TYPE
 M: M TYPE

C

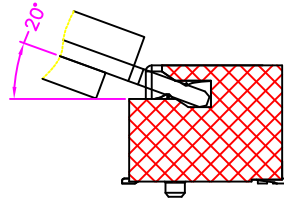
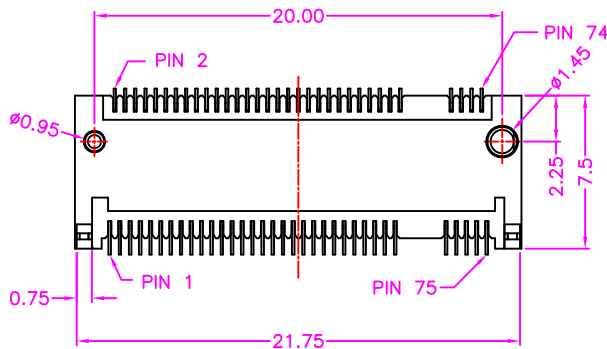

MATING SIMILAR

TAPE REEL PACKAGE

M	PIN 59-66	-6.125	14.0	2.0	14.0	1.5	1.125	1.375		
L	PIN 55-62	-5.125	13.0	3.0	13.0	2.5	1.125	1.375		
K	PIN 51-58	-4.125	12.0	4.0	12.0	3.5	1.125	1.375		
J	PIN 47-54	-3.125	11.0	5.0	11.0	4.5	1.125	1.375		
H	PIN 43-50	-2.125	10.0	6.0	10.0	5.5	1.125	1.375		
G	PIN 39-46	-1.125	9.0	7.0	9.0	6.5	1.125	1.375		
22110	108.25	F	PIN 28-35	1.625	6.5	9.5	6.0	9.5	1.375	1.125
2280	78.25	E	PIN 24-31	2.625	5.5	10.5	5.0	10.5	1.375	1.125
2260	58.25	D	PIN 20-27	3.625	4.5	11.5	4.0	11.5	1.375	1.125
2242	40.25	C	PIN 16-23	4.625	3.5	12.5	3.0	12.5	1.375	1.125
2230	28.25	B	PIN 12-19	5.625	2.5	13.5	2.0	13.5	1.375	1.125
3042	40.25	A	PIN 8-15	6.625	1.5	14.5	1.0	14.5	1.375	1.125
3030	28.25									
MODULE CARD TYPE	DIM P	KEY ID	PAD REMOVED	DIM A	DIM B	DIM C	DIM D	DIM E	DIM F	DIM G

D



TOLERANCES
 X.±0.40 .XX±0.20
 .X±0.30 .XXX±0.10

REV. A DRAWN BY Zhong 2019/10/18
 APPROVED BY Lion 2019/10/18

TITLE NGFF(M.2), 0.5mm PITCH, PCB MOUNT, SMT, 1 KEY WITH PAD H=5.80mm, FEMALE
 DRAW NO. MCEGT-005 UNIT MM Sheet 1/3

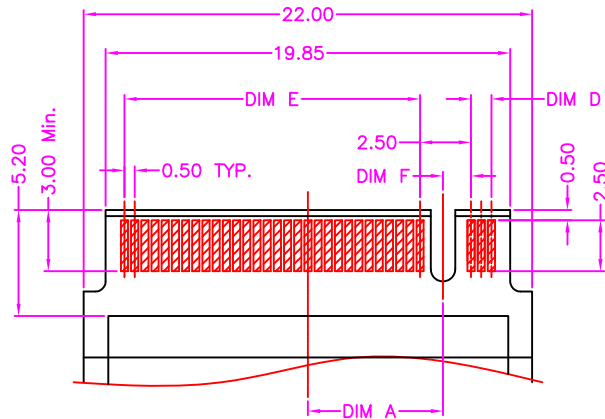

BOTTOM SIDE

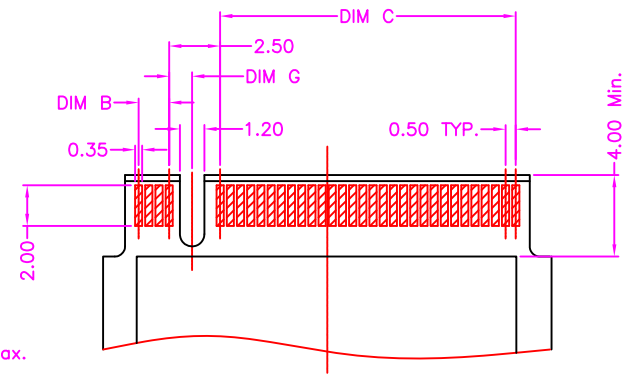
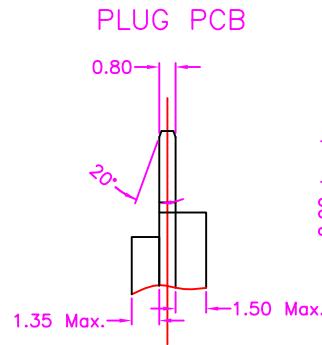

TOP SIDE

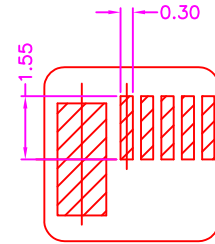
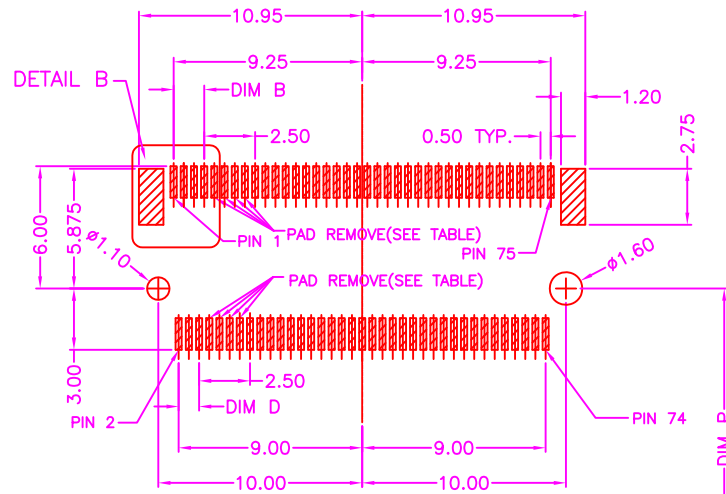

DETAIL B
SCALE 2:1

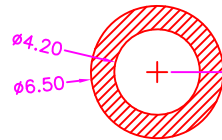

P.C.B. LAYOUT
TOP VIEW ± 0.05

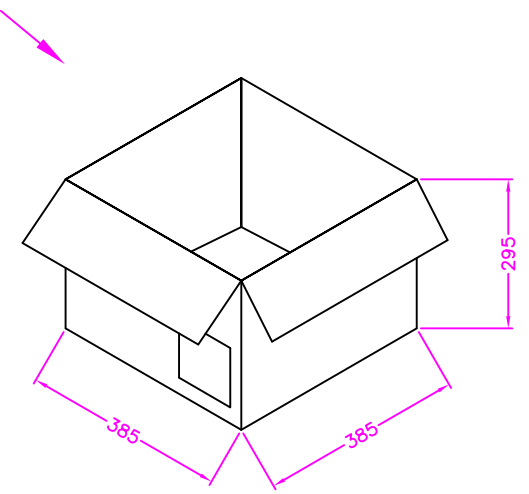
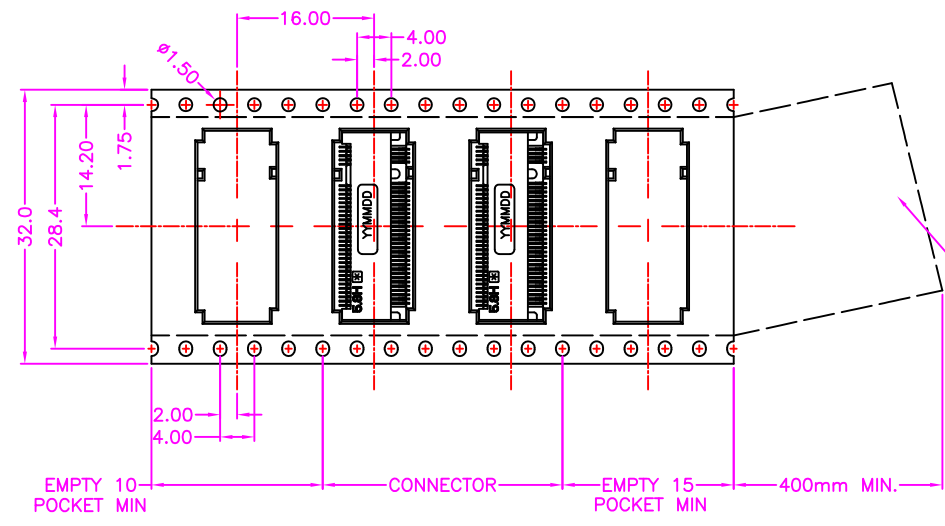
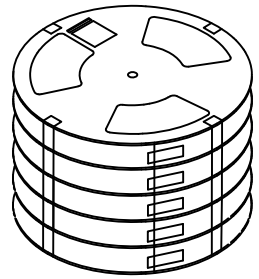
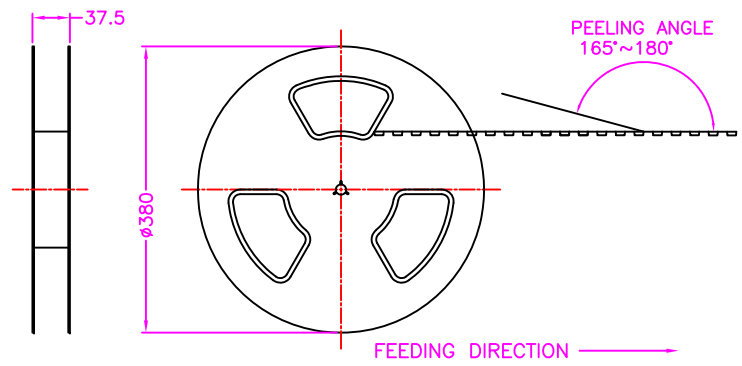

NOTE: 800PCS/ REEL, 4800PCS/ 6 REEL/ CARTON



TOLERANCES	
X.±0.40	.XX±0.20
.X±0.30	.XXX±0.10

REV.	A

DRAWN BY	Zhong 2019/10/18
APPROVED BY	Lion 2019/10/18

TITLE	NGFF(M.2), 0.5mm PITCH, PCB MOUNT, SMT, 1 KEY WITH PAD H=5.80mm, FEMALE				
DRAW NO.	MCEGT-005	UNIT	MM	Sheet	3/3