

P.C.B. LAYOUT  
TOP VIEW ±0.05

**MATERIALS**

HOUSING: LCP (UL 94V-0), BLACK  
 TERMINAL: COPPER ALLOY, GOLD PLATING ON CONTACT AREA  
 TIN PLATING ON SOLDER TAIL

**SPECIFICATION**

CURRENT RATING: 0.5 AMP MAX  
 DIELECTRIC WITHSTANDING: 500V AC FOR ONE MINUTE  
 CONTACT RESISTANCE: 100m OHMS MAX  
 INSULATION RESISTANCE: 1000M OHMS MIN AT DC 500V  
 OPERATION TEMPERATURE: -40°C~+85°C  
 COVER LOCKING FORCE: 4N~8N

PART NUMBER:

MMCPF - 0 8 \* T - 1 \* 5 \*

SERIES

NO. OF POS.

CONTACT PLATED OPTION

- 1: GOLD FLASH
- 3: 3u" GOLD
- 5: 5u" GOLD
- 7: 15u" GOLD
- 9: 30u" GOLD

POST OPTION  
 BLANK: WITHOUT POST  
 P: WITH POST

PACKAGE OPTION  
 2: TAPE REEL  
 3: TUBE

TIN PLATING ON SOLDER TAIL

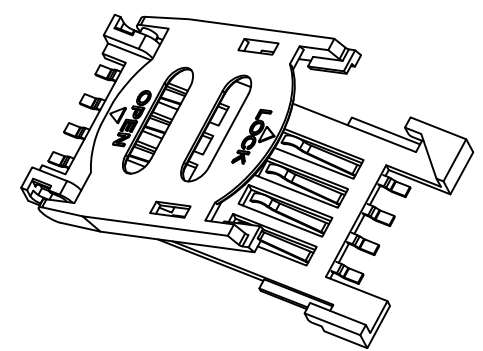

TOLERANCES	
X.±0.40	.XX±0.20
.X±0.30	.XXX±0.10

REV.	A	DRAWN BY	Zhong 2022/3/1	TITLE	SIM CARD, PCB MOUNT, SMT, ALL PLASTIC, HINGE TYPE, 8 PIN, WITH POST FEMALE				
		APPROVED BY	Lion 2022/3/1	DRAW NO.	MMCPF-005	UNIT	MM	Sheet	1/2

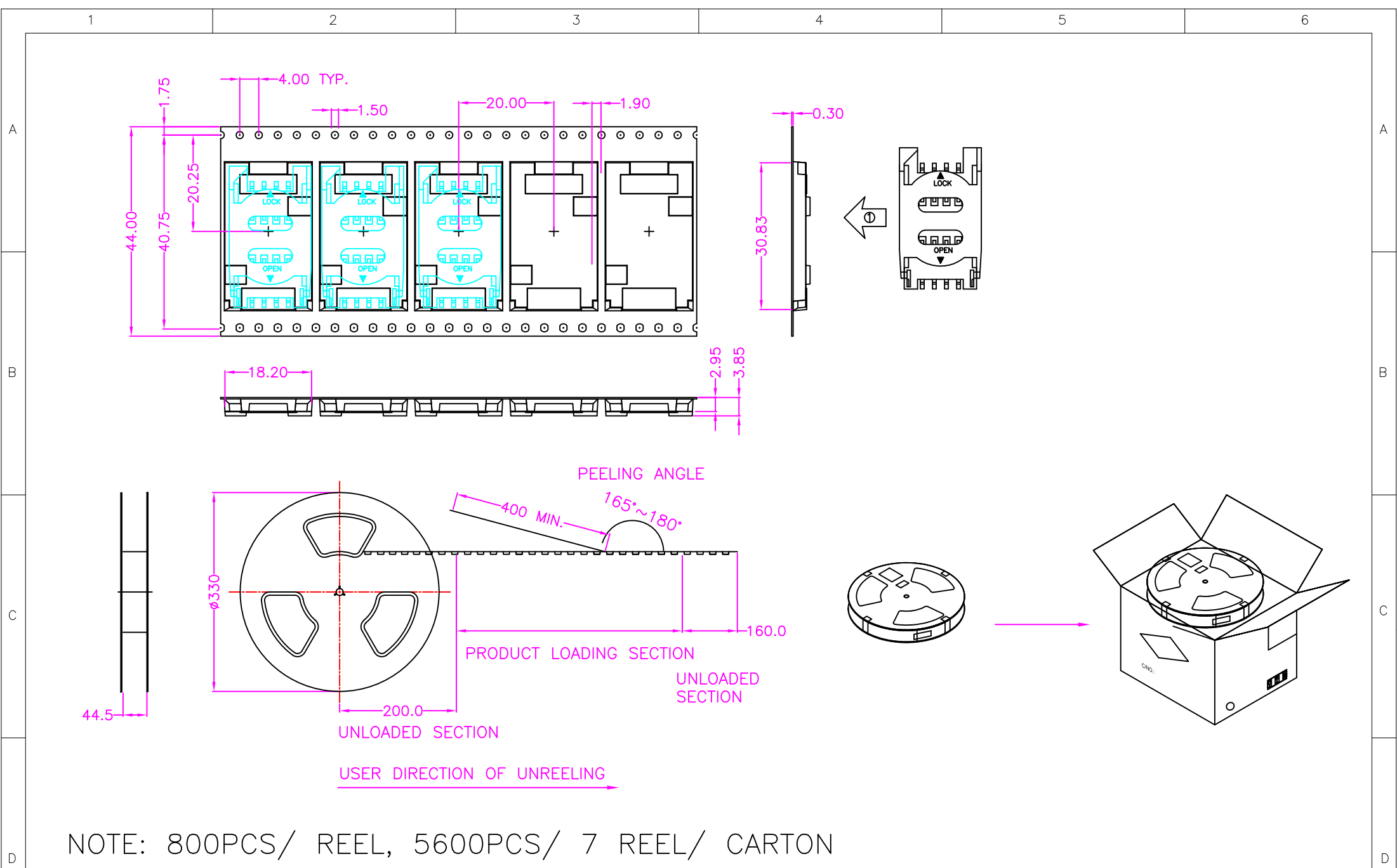

NOTE: 800PCS/ REEL, 5600PCS/ 7 REEL/ CARTON