

A

B

C

D

A

B

C

D

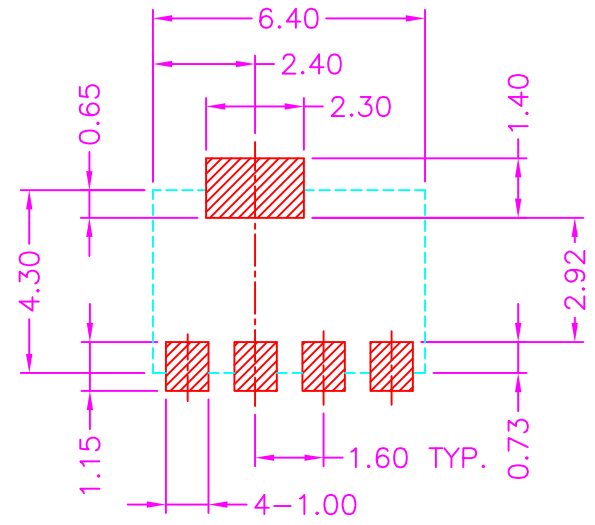
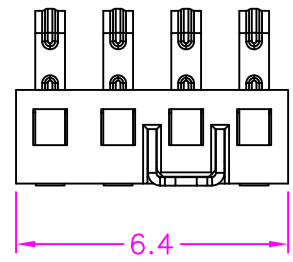
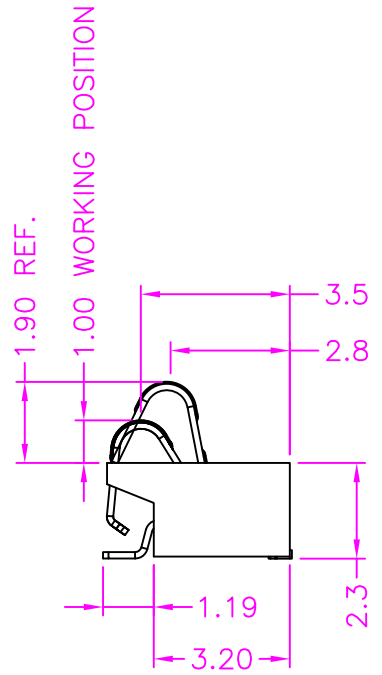
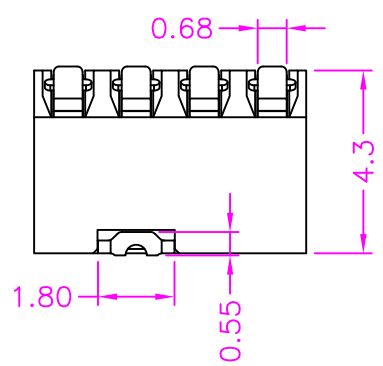
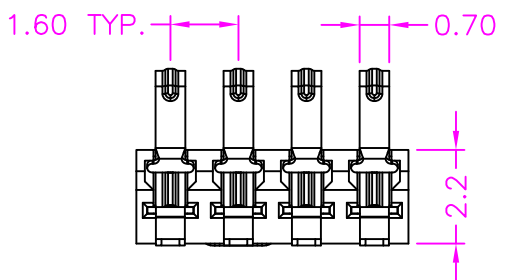
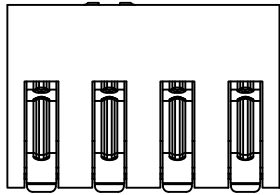

P.C.B. LAYOUT  
TOP VIEW ±0.05

**MATERIALS**

HOUSING: LCP (UL 94V-0), BLACK  
 SOLDER PAD: STAINLESS STEEL, TIN PLATING  
 TERMINAL: COPPER ALLOY, GOLD PLATED

**SPECIFICATION**

CURRENT RATING: 1 AMP MAX  
 DIELECTRIC WITHSTANDING: 350V AC FOR ONE MINUTE  
 CONTACT RESISTANCE: 30m OHMS MAX  
 INSULATION RESISTANCE: 1000M OHMS MIN AT DC 500V  
 OPERATION TEMPERATURE: -40°C~+85°C

**PART NUMBER:**

ABTNH - 0 4 \* - 1 2 2

SERIES ——— NO. OF POS. ——— TAPE REEL PACKAGE

**CONTACT PLATED OPTION**

- 1. GOLD FLASH
- 3. 3u" GOLD
- 5. 5u" GOLD
- 6. 10u" GOLD
- 7. 15u" GOLD
- 9. 30u" GOLD



TOLERANCES	
X.±0.40	.XX±0.20
.X±0.30	.XXX±0.10

REV.	A	DRAWN BY	Kiki 2023/8/4	TITLE	BATTERY, 1.60mm PITCH, PCB MOUNT, VERTICAL SMT, 4PIN, FEMALE				
		APPROVED BY	Lion 2023/8/4	DRAW NO.	ABTNH-002	UNIT	MM	Sheet	1/1