

MATERIALS

HOUSING: HI-TEMP. PLASTIC (UL 94V-0), BLACK
 SHELL: STAINLESS STEEL, NICKEL PLATING
 TERMINAL: COPPER ALLOY, GOLD PLATED
 O-RING: SILICONE RUBBER

SPECIFICATION

CURRENT RATING:
 1.5A/PIN MAX (A4,A9,B4,B9)
 1.25A/PIN MAX (A1,A12,B1,B12)
 0.25A FOR ALL THE OTHERS CONTACTS
 DIELECTRIC WITHSTANDING: 300V AC FOR ONE MINUTE
 CONTACT RESISTANCE: 40m OHMS MAX
 INSULATION RESISTANCE: 100M OHMS MIN AT DC 300V
 OPERATION TEMPERATURE: -40°C~+85°C

PART NUMBER:

BUSJT - 1 6 * - 1 2 4

SERIES

NO. OF POS.

CONTACT PLATED OPTION

- 1: GOLD FLASH
- 3: 3u" GOLD
- 5: 5u" GOLD
- 6: 10u" GOLD
- 7: 15u" GOLD
- 9: 30u" GOLD

TAPE REEL PACKAGE



TOLERANCES	
X.±0.40	.XX±0.20
.X±0.30	.XXX±0.10

REV.	A

DRAWN BY	Fanny 2021/6/3
APPROVED BY	Lion 2021/6/3

TITLE	USB C TYPE, PCB MOUNT, WATERPROOF, SMT, METAL SHIELD, 16PIN FEMALE (IPX6)
DRAW NO.	BUSJT-004

UNIT	MM	Sheet	1/2
------	----	-------	-----

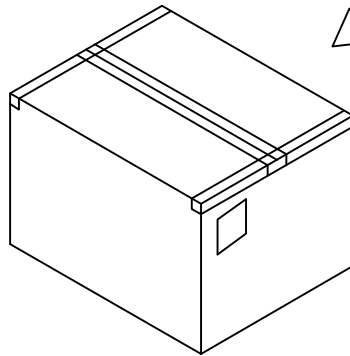
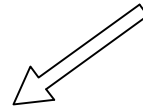
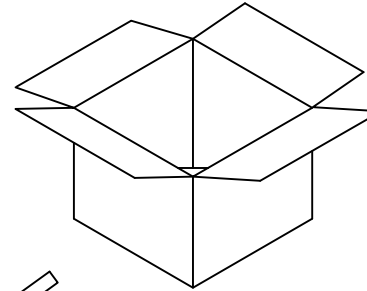
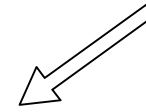
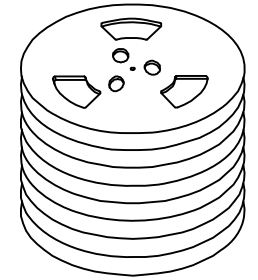
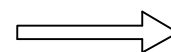
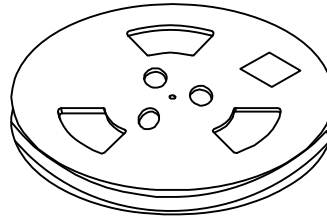
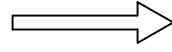
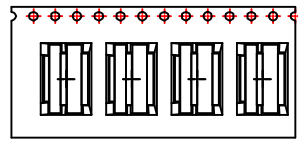
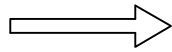
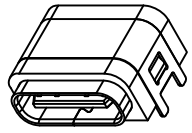

PIN ASSIGNMENT:

Pin No.	Signal Name	Pin No.	Signal Name
A1	GND	B12	GND
A2		B11	
A3		B10	
A4	VBUS	B9	VBUS
A5	CC1	B8	SBU2
A6	D+	B7	D-
A7	D-	B6	D+
A8	SBU1	B5	CC2
A9	VBUS	B4	VBUS
A10		B3	
A11		B2	
A12	GND	B1	GND

NOTE: 700 PCS/ REEL, 7000 PCS/ 10 REEL/ CARTON